

# Channel Sensitivity Analysis in a Ventricular Myocyte Model



**BRIAN BECERRA**  
**MONASH UNIVERSITY**  
**JULY 30<sup>TH</sup>, 2012**

# Project Proposal



- Utilizing Shannon-Bers' ventricular myocyte model, through Matlab and Nimrod, this project aims to analyze the various parameters that are associated with each ionic channel in the cell. This analysis will be used to determine the effect and importance of each parameter on each channel. This analysis can eventually be used to aid in determining the best targets for pharmacological systems.

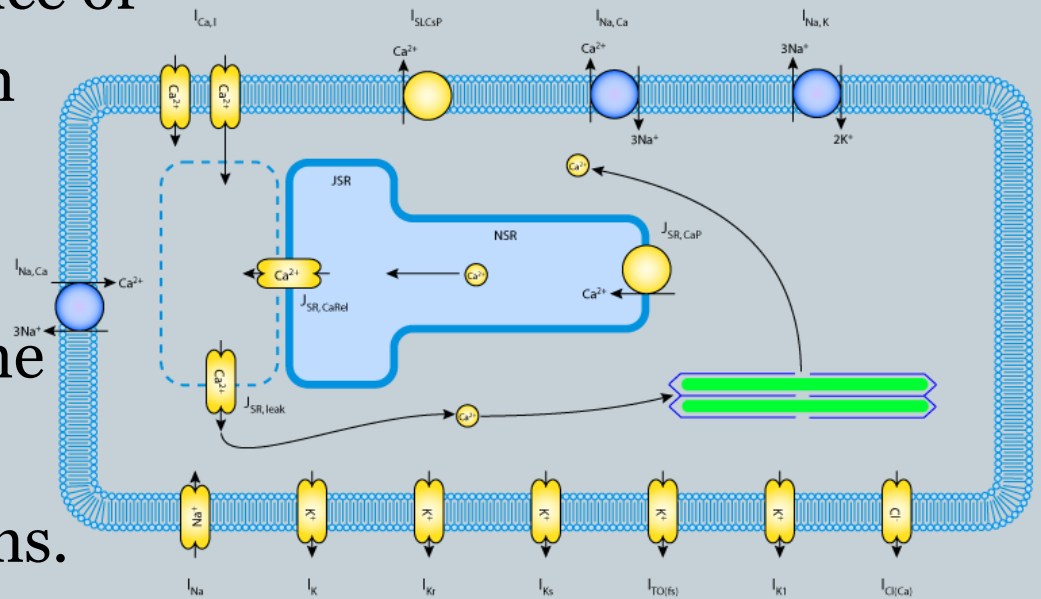

# Progress



- Finished up re-adjusting parameter sweeps for ventricular myocyte, according to the new experimental design
  - Just found a problem with the new sweeps, may have to adjust
- Began going over computational statistics sources
  - Box, Hunter, and Hunter-Statistics for Experimenters
  - Bruning and Kintz-Computational Handbook of Statistics
- Blair started to fix old version of Nimrod/E, and is going to use one of the ion channels as a reference
  - Channel I\_Ks

# Tentative Plans



- Hopefully, will have Nimrod/E working, to begin post-analysis
- Will continue to read Statistics sources
- After finishing the sweeps, realized that as opposed to the pre-new experimental design, the collation of one of the outputs did not come out correctly
  - May have to adjust the plan file, so that the results mimic the original outputs

# Plans for the next 2 weeks



- Make sure that all results are collated correctly, so they can be accurately analyzed
- Once Nimrod/E is working, will be able to begin post-analysis of results
- Once post-analysis is completed, will be able to determine the significance of each parameter

# My Project's Journey



## Successes!

- Able to tweak old experiments, so that they work with the new experimental design

## Roadblocks

- Found a problem with the first, new experimental design sweep, but did not show up as an error
  - Appears to be a problem with the plan file; still has an output, without any errors, just not the correct collation





Chill lounge, where EVERYTHING is made of ice!



Even the ants are huge over here



Malaysian food



Before my lacrosse game, which I play in every Saturday. Go Chaddy!

# Acknowledgements



- UCSD PRIME and AIP
  - Gabriele Wienhausen
  - Peter Arzberger
  - Teri Simas
  - Tricia Taylor.
- Monash University
  - David Abramson
  - Blair Bethwaite
  - All the lab members!
- UCSD Bioengineering
  - Anushka Mihailova

**PRIME**

PACIFIC RIM UNDERGRADUATE EXPERIENCES



**MONASH**  
University

